

## Troubleshooting:

No.	Symptoms	Troubleshooting steps	Process
1	No light at night	Check that the lamp can be manually activated.	Refer to "Activation and Installation" section on this user guide and run activation tests.
		Check if the solar panel is blocked from the sunlight by houses, trees and other obstacles.	Clear obstructions or change installation location.
		Check if there is any artificial light source(s) shining on the solar panel during the night.	Remove the artificial light source(s) of interference or change the installation location.
		Examine status of each component based on the repair guide.	Replace the damaged component(s).
2	A serious shortage of working time	Check if the solar panel is blocked from the sunlight by houses, trees and other obstacles.	Clear obstructions or change installation location.
		Check if the surface of the solar panel is dusty or covered.	Clean the surface of solar panels as detailed above.
		Examine if the battery pack is damaged as per the repair guide instructions.	Replace damaged battery.
3	Lighting does not follow the normal operating mode of turning on and off		Replace damaged battery.
4	Lights fail to turn on properly when humans approach	Check if the air temperature close to human body temperature.	When the air temperature is close to human temperature, motion detection may slow down. It will return to normal after the air temperature changes.
		Check if the installation height is too high.	It is out of motion detection range when installation height exceeds 8m. It is recommended to reduce the height or use other operating modes.
			Replace damaged motion sensor or controllers.

# PBOX X5



## All-in-One Solar Street Light User Manual

Thank you for choosing the PBOX X5 Series Solar Street Light. For any questions, please email us at [sales@pboxlighting.com](mailto:sales@pboxlighting.com).

Please refer to the actual products if the provided diagrams show slight differences.

# PBOX X5

[www.pboxlighting.com](http://www.pboxlighting.com)



## Before using the X5 Solar Street Light, carefully read the following precautions to avoid damage or errors.



### Precautions

#### Operating Conditions & Limits:

This product is rated as IP65 protection grade. Do not exceed the stated operating limits. The operating temperature range is from -20°C to 60°C and the charging temperature limit is within 0 to 60°C. If equipped with heating features, it may be used between -40°C and 60°C. The heavy-duty structure will survive up to a Category 12 typhoon or cyclone. (Storms above Category 12 may cause damages to the product).

#### Transportation & Storage:

This product contains lithium batteries. Please follow air transport regulations when shipping. It should be regarded as potentially flammable and explosive, and be isolated from other goods when stored, so as to avoid any damage.

The solar panels of this product should be considered as fragile. There should never be more than 4 layers of boxes when stacked. To avoid damage to the panels, make sure no heavy pressure is applied to the boxes.

Please store the product in temperature between 0°C to 45°C.

If stored for a long period, the product should be recharged every 6 months. Please only use the special charger (purchased from manufacturer) to avoid damage to the battery or device.

When repackaging the product after inspection or charging, set the light into sleep mode by holding the on/off button for 5 sec. The light will flash three times to signal that it has properly entered sleep mode. You may now repackage the product into its box. To exit sleep mode, either press the on/off button one more time, or wait an hour for the light to reboot automatically through contact with sunlight.

#### Product Maintenance:

To ensure effective solar light absorbance, clean the surface of the panels regularly with water and a soft cloth. Do not use chemical solutions or abrasives.

This Solar Street Light operates on a low voltage DC current. Unless customized otherwise, do not connect components or ports to an AC current or any higher rated DC voltage.

Do not replace the original unit with unauthorized third party parts as they may cause serious damage to the product. To order replacement parts or to have them fitted, please visit [www.pboxlighting.com](http://www.pboxlighting.com) or contact your local distributor.

#### Product Recycling:

This product is made from recyclable, high-performance materials. All materials are compliant to the ROHS standard. Do not dispose of this product with other household waste.

Please check your local regulations on collection and disposal of electronic items. Proper disposal of used product helps prevent negative impacts on the environment.



RoHS  
COMPLIANT

IP65



## Product Manual:

### Parts & Functions:

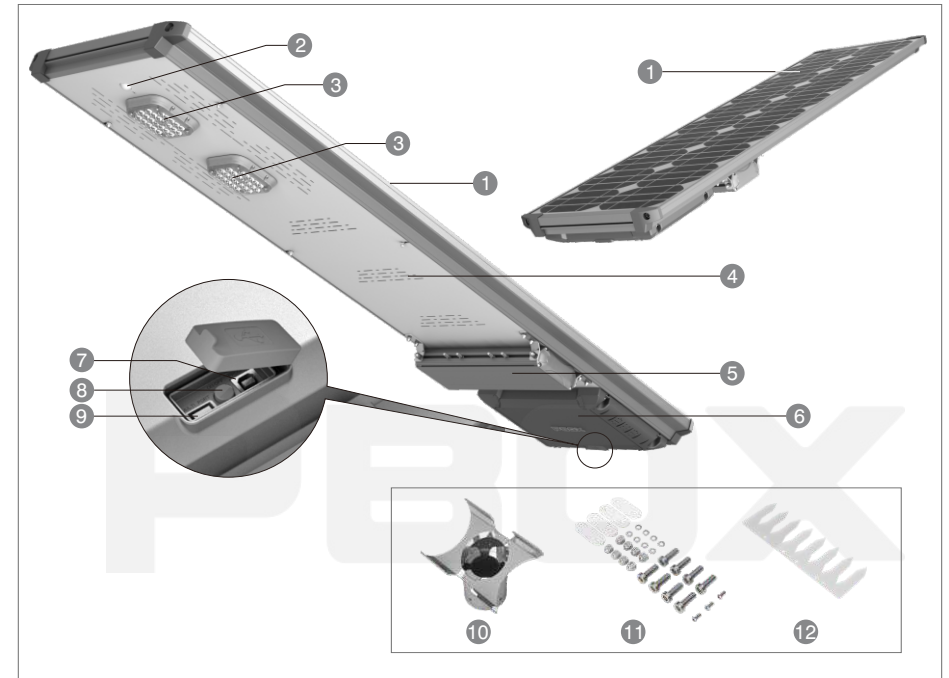

No.	Parts	Functions
1	Solar panel	Absorbs and converts solar energy into electricity
2	Motion sensor	Detects human movement
3	LED light	Lights the area
4	Vents	Heat dissipation
5	Bracket support	For combination with X bracket
6	Control box	Battery (charge / discharge) management
7	Type B USB connector female	For program input
8	On/off button	During daytime, press to reboot the system; During nighttime or when ambient light illumination is below 30lx, press to turn the street light on/off
9	Type A USB Connector Female	For battery charging via a 14VDC 1.5A power supply (Optional - to be purchased from manufacturer)
10	X bracket	Fixes solar light unit
11	Bracket buckles 4pcs/ M6 cap nuts 8pcs/ M6 spring washers 8pcs/ M8X25 screws 8pcs/ self-tapping screws 3pcs	Fixes solar light unit, and bird spike in place
12	Bird spike	Prevents solar panel contamination from bird droppings

## Factory settings and motion detection functions:

The factory setting of the PBOX X5 switch is light-controlled (at a threshold of 30 Lux). The lamp automatically lights up when it is dark and turns off when there is light or at dawn. At night, when no one is around, it operates under power saving mode. When anyone approaches, its brightness increases by a factor of four. If the air temperature is close to human temperature, the motion detection may reduce in sensitivity.

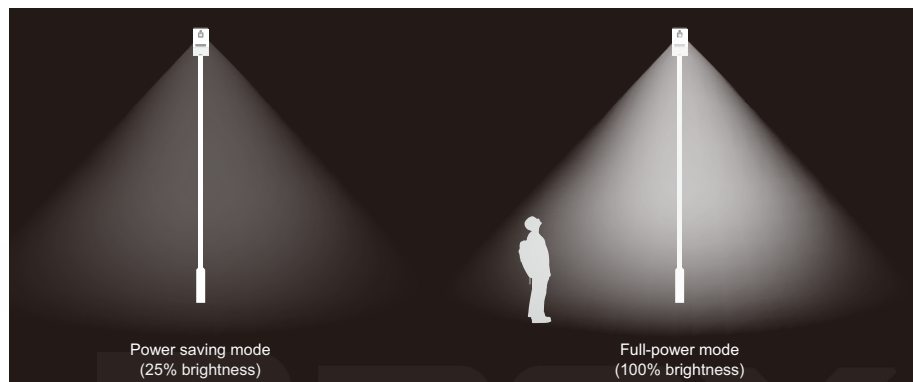

## Installation:

### 1. Environment:

- a Please select the appropriate product according to the installation site's sunlight intensity and required operating time. If you are in the northern hemisphere, face the solar panels towards the south as far as possible when installing the X5; if you are in the southern hemisphere, face the solar panels towards the north.

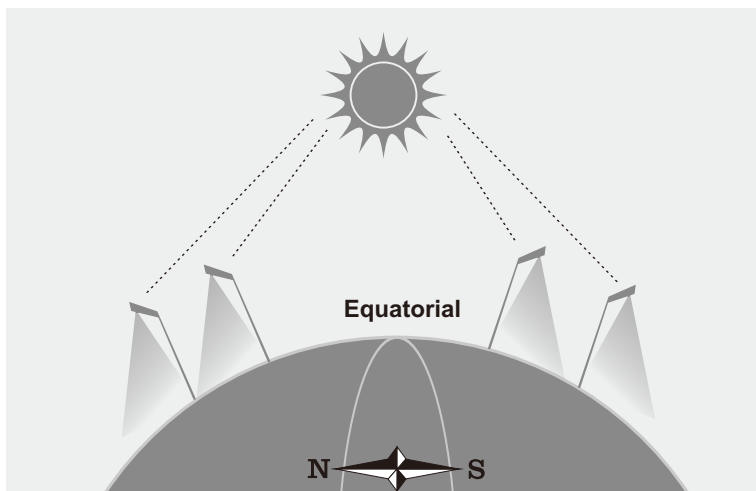

- b For maximum operation efficiency of the solar panels, make sure the sunlight is not blocked by buildings or trees.

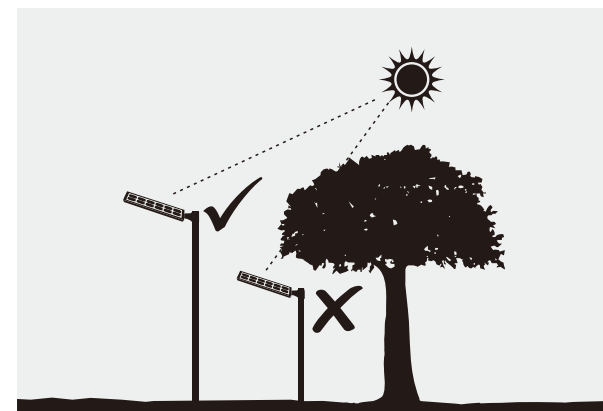

### 2. Altitude and distance parameters:

Install according to the height and distance (between the lamps) restrictions as set by each respective product type. Consult our product specialists for special lighting requirements.

Power	Bat wing light source		Round beam light source	
	Height of posts	Distance between posts	Height of posts	Distance between posts
15W	3~5m	12~20m	3~5m	8~14m
20W	4~7m	15~30m	4~7m	10~18m
30W	5~8m	25~35m	5~8m	14~20m
50W	6~8m	30~40m	6~8m	15~25m

## Activation and installation:

### Activation test:

- \* **Automatic Daytime Activation:** Remove the X5 Solar street light from its box. If there is adequate outdoor light, the lamp will illuminate for 20 seconds and then turn off, this means the system has been successfully activated. (During weak daylight or night time, please refer to the manual night time activation below).
- \* **Manual Night time Activation:** If installing the X5 at night or in a weak light environment, press the On/Off button. If the lamp lights up, this indicates the system has been successfully activated.

⚠ When the USB is not in use, close it properly with the cap in order to avoid damaging the controller through dampness or water.



### Openings on post:

At 65 mm from the top of the pole, drill a 10mm hole for fixing the X bracket. (See Figure 1)

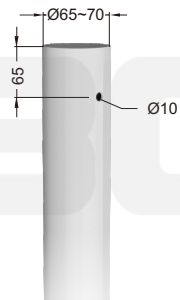

Figure 1

### Installation:

- 1 **Install X bracket:** Fix the bracket to the bracket support with the 8 screws buckles, M6 spring washers, and M6 cap nuts. (See Figure 2)

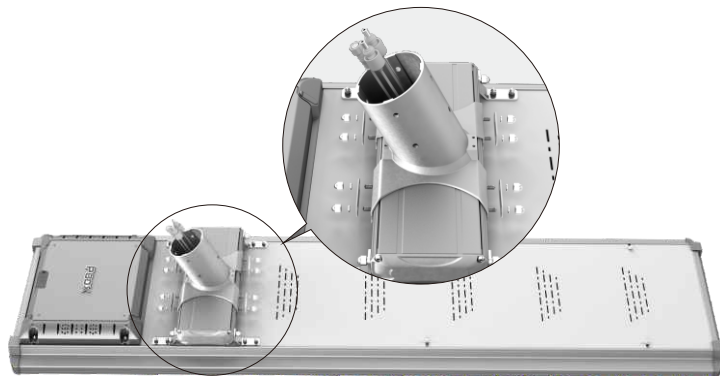

Figure 2

- 2 **Bird spike:** Use 3 self-tapping screws to fix the bird spike along the rim of the top of the light. (See Figure 3)

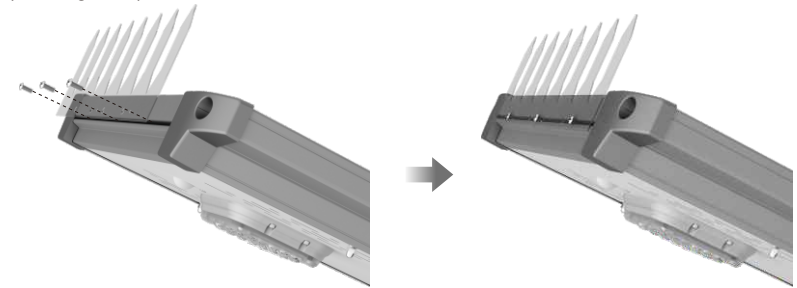

Figure 3

- 3 **Install light:** Fix the light unit to the pole with M8X25 screws. The maximum torque for those M8X25 bolts is 14Nm. Do not surpass this torque specification. (See Figure 4)



Figure 4